

9V(6LR61)
General Features

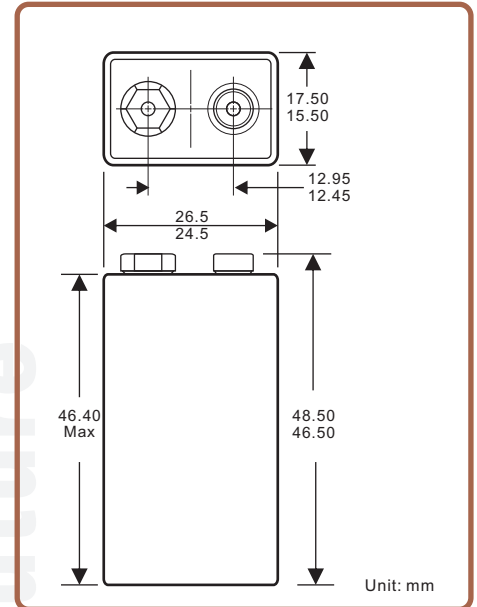

▶ Designation	IEC-6LR61 JIS-6AM6 ANSI-1604A Others-9V,MN1604
▶ Chemical system	Alkaline-Manganese Dioxide ※No added Mercury and Cadmium
▶ Nominal Voltage	9.0V
▶ Weight	Approx.53.2g
▶ Terminal	Miniature snap
▶ Storage Temperature Range	-20°C~35°C
▶ Operating Temperature Range	-20°C~54°C
▶ Jacket	Metal
▶ Shelf Life	5 years(20±2°C , 80% of rated capacity)
▶ Standards	IEC60086 2006/66/EC



Electrical Characteristics

CONDITION	OCV (V)	CCV (V)	SCC (A)
Fresh Battery	9.3~9.9	7.60	3.0
After 3 mths	9.2~9.6	7.40	2.7
After 12 mths	9.1~9.6	7.40	2.5

Test Conditions Load resistance:47Ω±0.5%; Measuring time:0.2S; Temperature:20±2°C

Discharge Characteristics: (20±2°C, RH:45%~75%)

Standard	Discharge Condition			Average Discharge Time		
	Discharge Load	Discharge Time	E.P.V.	Fresh Battery	After 12mths	After 36mths
IEC	180Ω	0.5h/d	4.8V	11.0h	10.1h	9.5h
IEC	270Ω	1h/d	5.4V	17.0h	15.6h	14.4h
IEC	620Ω	2h/d	5.4V	40.0h	36.8h	34.0h
REF	900Ω	4h/d	5.4V	55.0h	50.0h	48.0h

Constant Resistance Performance

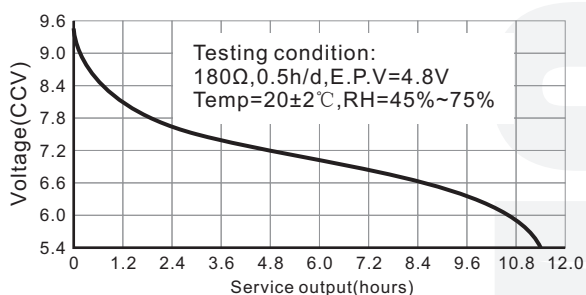

Constant Resistance Performance

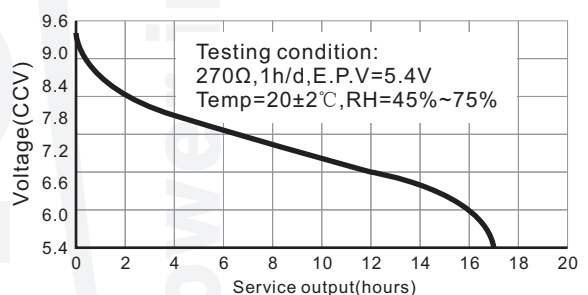

Constant Resistance Performance

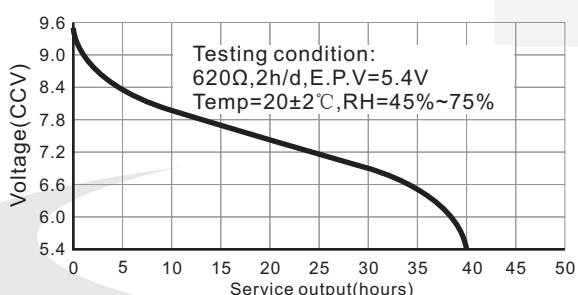

Constant Resistance Performance

