

D(LR20)

General Features

▶ Designation	IEC-LR20 JIS-AM1 ANSI-13A Others-D,E95,MN1300
▶ Chemical System	Alkaline-Manganese Dioxide ※No Mercury and Cadmium added
▶ Nominal Voltage	1.5V
▶ Weight	Approx.136g
▶ Terminal	Flat
▶ Storage Temperature Range	-20°C~35°C
▶ Operating Temperature Range	-20°C~54°C
▶ Jacket	Foil jacket
▶ Shelf Life	5 years(20°C, 80% of rated capacity)
▶ Standards	IEC60086 2006/66/EC GB8897

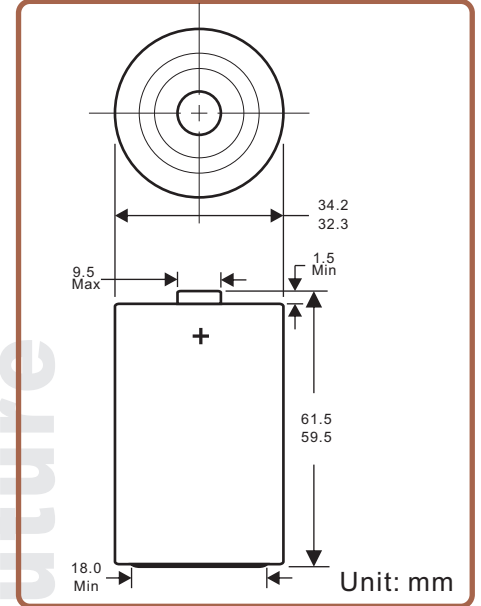

Electrical Characteristics

CONDITION	OCV (V)	CCV (V)	SCC (A)
Fresh Battery	1.62	1.50	14
After 3 mths	1.60	1.45	12
After 12 mths	1.60	1.45	11

Test Conditions: Load resistance:2.2Ω±0.5%; Measuring time:0.2S; Temperature:20±2°C.

Discharge Characteristics: (20±2°C,RH:45%~75%)

Standard	Discharge Condition				Average Discharge Time		
	Appliances	Discharge Load	Discharge Time	End Voltage	Fresh Battery	After 12mths	After 36mths
IEC	Radio	10Ω	4h/d	0.9V	100h	95.0h	87.0h
IEC	Electric toy	2.2Ω	1h/d	0.8V	19.5h	18.2h	17.0h
IEC	Portable lighting	2.2Ω	4m/h,8h/d	0.9V	24.0h	22.0h	20.0h
IEC	walkman	600mA	2h/d	0.9V	15.0h	14.0h	12.0h
IEC	---	2.2Ω	24h/d	0.9V	18.0h	17.0h	16.0h

Security Characteristics: (20±2°C,RH:45%~75%)

NO	Test Item	Test Method	Sample QTY.	Standard
1	Over discharge-leakage-proof test	20±2°C,RH60±15%;2.2Ω continuous discharge to 0.6V; visual observation	9pcs	No leakage
2	High temperature-leakage-proof test	Store for 28 days under 60±2°C and RH:90±5%; then store for 4~24 hours under 20±2°C and RH: 60±15%	20pcs	No leakage
3	External short-circuit	20±2°C,RH=60±15%;keep the battery external short-circuit for 24hours under the specified conditions	10pcs	No explosion
4	Improper Installation	20±2°C,RH60±15%;keep four un-discharged batteries from the same batch series connected with one of them(the test battery)reversed	5groups	No explosion

Constant Resistance Performance

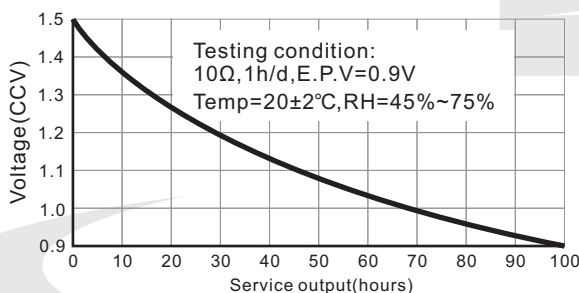

Constant Resistance Performance

