



**TECHNICAL SPECIFICATION FOR
LI-ION CYLINDRICAL RECHARGEABLE BATTERY**

LCR26650-5000MAH

FILE NO.: DSE-LCR26650-5A-V18A

EDITION.: V18A

DATE.: 2018/03/04

Prepared By	Checked By	Approved By
QE1	QE	A

MOTOMA POWER CO.,LTD

Http: // www.motoma.com E-mail:info@motoma.com

Manufacturer reserves the right to alter or amend the design, model and specification without prior notice.

1. SCOPE

This product specification describes the nominal specification, technical requirement, testing method, warning and caution of the Li-ion rechargeable battery, which is manufactured by MOTOMA POWER CO.,LTD.

2. BATTERY MODEL

LCR26650 5000mAh

3. NOMINAL SPECIFICATION

3.1 Nominal voltage	3.7V
3.2 Nominal capacity	5000mAh
3.3 Minimum capacity	5000mAh
3.4 Charging	
Constant Current and Constant Voltage (CC/CV)	
Charge voltage	4.2V
Standard charge current	1000mA (0.2C)
End current	50mA (0.01C)
Max. charge current	2500mA (0.5C)
3.5 Discharging	
Standard discharge current	1000mA (0.2C)
Max. discharge current	5000mA (1C)
End voltage of discharge	3.0V
3.6 Cycle Life	
Discharge capacity (500th Cycle) ≥80% of Initial Capacity(0.2C)	
3.7 Operate temperature range (relative humidity: 45%~75%)	
Standard charge	0~45°C
Discharge:	-20~60°C
3.8 Storage (relative humidity: 45%~75%)	
Less than 30 days	-20~45°C
Less than 180 days	-20~35°C
3.9 Internal Impedance	≤30mΩ
3.10 Weight	Approx. 86g
3.11 Dimensions	Shown in the page 6

4. APPEARANCE PERFORMANCE

There shall be no practical damage such as conspicuous liquid electrolyte leakage, flow and dirt under conditions of storage or operation as specified herein.

5. BATTERY CHARACTERISTICS

5.1 Testing conditions

Test should be conducted with new batteries within one month after shipment from our factory and the cells shall not be cycled more than five times before the test. Unless otherwise defined, test and measurement shall be done under temperature of $25\pm 2^{\circ}\text{C}$ and relative humidity of 45~85%.

5.2 Measurement apparatus

5.2.1 Dimension measuring instrument

The dimension measurement shall be implemented by instruments with equal or more precision scale of 0.02mm.

5.2.2 Voltmeter

Standard class specified in the national standard or more sensitive class having inner impedance not less than 10 K Ω /V.

5.2.3 Ammeter

Standard class specified in the national standard or more sensitive class. Total external resistance including ammeter and wire is less than 0.01 Ω .

5.2.4 Impedance meter

Impedance shall be measured by a sinusoidal alternating current method(AC 1kHz).

5.3 Charging procedure for test purpose

The battery shall be charged at an ambient temperature of $20\pm 5^{\circ}\text{C}$ at a constant current of 1000mA (0.2C) until the battery voltage reaches 4.2V, then charge at constant voltage of 4.2 V while tapering the charge current. Charging shall be terminated when the charging current has tapered to 50mA (0.01C).

5.4 Discharging performance

TABLE I: Discharging performance at 20°C

Constant Discharge Current Rate	Constant Discharge Current	End Point Voltage	Discharge Duration	Available Capacity
0.2C	1000mA	3.0V	300min	100%
0.5C	2500mA	3.0V	120min	100%
1.0C	5000mA	3.0V	60min	100%

※**Note:** All the testing should be done within 1 hour after being standard charged.

5.5 Temperature characteristics

Battery shall meet the discharge capacity requirements at different discharge temperature as showed in the follow table. The capacities are to be measured with constant discharge current on 0.2CmA (3.0V cut-off) after standard charge at $25\pm 2^{\circ}\text{C}$.

TABLE 2: Temperature Characteristics

Discharge Temperature	0°C	25°C	60°C
Available Capacity	60%	100%	95%

Manufacturer reserves the right to alter or amend the design, model and specification without prior notice.

5.6 Charge retention

TABLE 3: Charge retention

Item	Measuring Procedure	Requirements
Storage Characteristics (25°C)	The capacity on 0.2C discharge shall be measured after standard charge and then to be stored at 25±2°C for 30 days.	Retention Capacity ≥85%
	To measure the Retention Capacity after the battery to be cycled on 1.0C for three times.	Retention Capacity ≥90%
Storage Characteristics (60°C)	The capacity on 0.2C discharge shall be measured after standard charge and then to be stored at 60±2°C for 7 days.	Retention Capacity ≥60%
	To measure the Retention Capacity after the battery to be cycled on 1.0C for three times.	Retention Capacity ≥80%

5.7 Endurance in cycles

10min rest period after being standard charged, discharge the battery at a current of 0.2C to 3.0V, rest 10min, the capacity shall be measured after 500cycles of standard charge and discharge at 25±2°C.

Discharge capacity (500th Cycle) ≥80% of Initial Capacity

10min rest period after being standard charged, discharge the battery at a current of 1.0C to 3.0V, rest 10min, the capacity shall be measured after 300cycles of standard charge and discharge at 25±2°C.

Discharge capacity (500th Cycle) ≥75% of Initial Capacity

5.8 Mechanical performance

TABLE 4: Mechanical performance

Item	Measuring Procedure	Requirements
Vibration test	After standard charge, the battery is to be tested as following conditions: Amplitude:0.8mm Frequency:10~55Hz(sweep:1Hz/min) Direction: X/Y/Z axis for 90~100min. The battery is to be tested in three mutually perpendicular to each axis.	No fire, no explosion, no smoking is obtained.
Drop Test	Drop the battery in the shipment condition(full-charge) from 1.2m height onto 5cm or thicker concrete with p-tile on it 1 times each of X, Y, and Z directions at 25±2°C	No fire, no explosion, no smoking is obtained.

5.9 Safety performance

TABLE 5: Safety performance

Item	Measuring Procedure	Requirements
Overcharge Test	After standard charge (Section 4.4), the battery shall be charged at 2C/4.6V for 8.0hrs.	No fire, no explosion, no smoking is obtained.
Short circuiting Test	After standard charge (Section 4.4), the battery shall be subjected to a short-circuit condition with a wire of resistance less than 100mΩ for 1 hour.	No fire, no explosion, no smoking is obtained.
Over discharge Test	After discharged to the cut-off voltage, the battery shall be subjected to a short-circuit condition with a load of resistance less than 30Ω for 24hour.	No fire, no explosion, no smoking is obtained.
Heating Test	A battery is to be heated in a gravity convection or circulating air oven. The temperature of the oven is to be raised at a rate of $25 \pm 2^{\circ}\text{C}/\text{min}$ to a temperature of $130 \pm 2^{\circ}\text{C}$ at which temperature the oven is to remain for 30 minutes before the test is discontinued.	No explosion, no fire.

5.10 Storage characteristics

After standard charged as 5.3, store the testing cells at $20^{\circ}\text{C} \pm 5^{\circ}\text{C}$ for 28 days. Then discharge at 0.5C to 3.0V. The discharge capacity $\geq 80\%$ of Initial capacity.

6. ENVIRONMENTAL PROTECTION REQUIREMENT

- 6.1 The requirement on Hazardous Substances in the materials should comply with MOTOMA standard on HSF (Hazardous Substance Free).
- 6.2 The requirement on Hazardous Substances in the Products should comply with 2006/66/EC and MOTOMA standard on HSF.

7. SHIPPING

The capacity of delivery battery is approximately at 80% of charging. During transportation, keep the battery from acutely vibration, impacting, solarization, drenching.

8. OTHERS

Any matters that this specification does not cover should be conferred between the customer and MOTOMA.

9. ASSEMBLY DRAWING

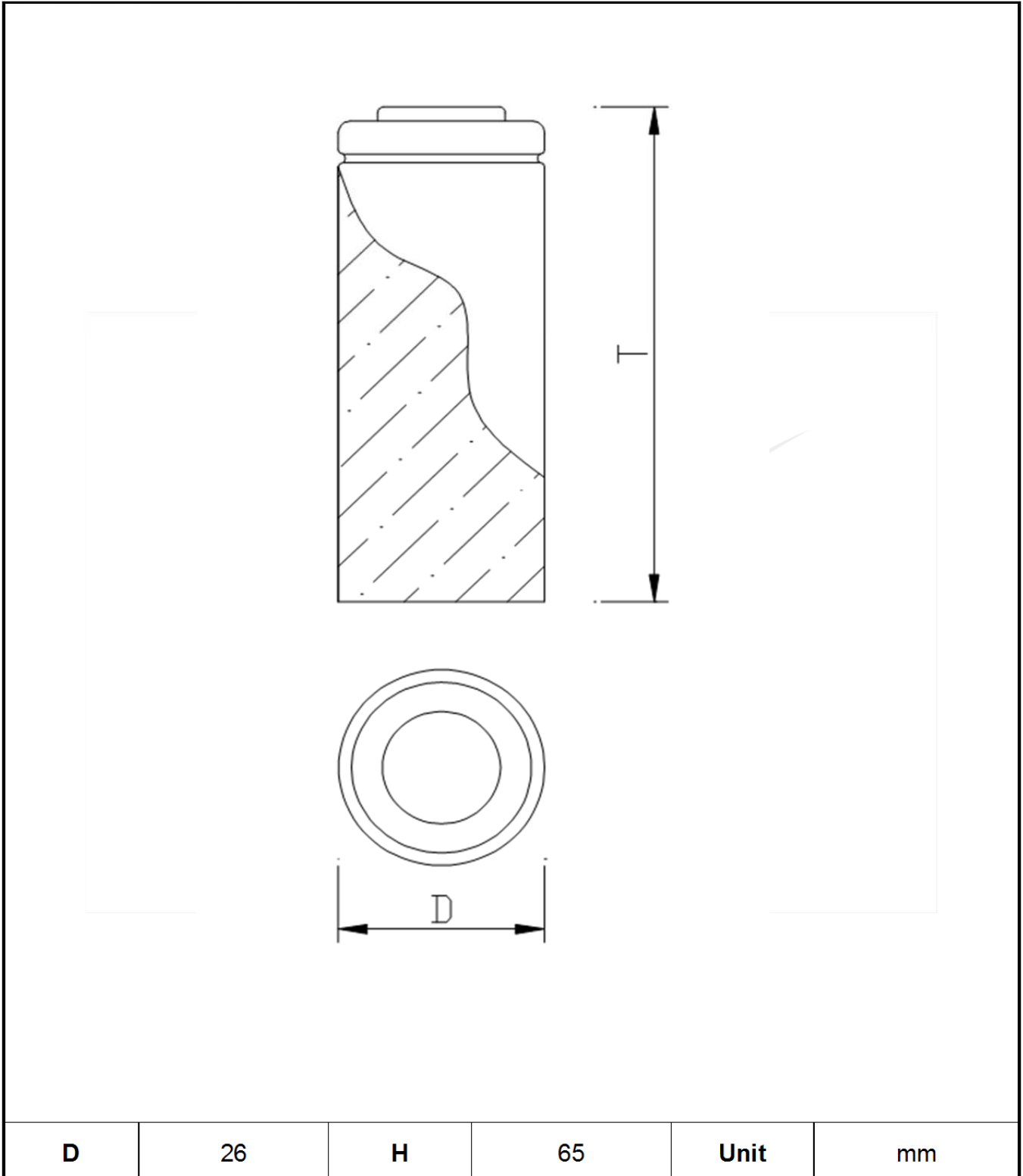

10. PERFORMANCE CURVE

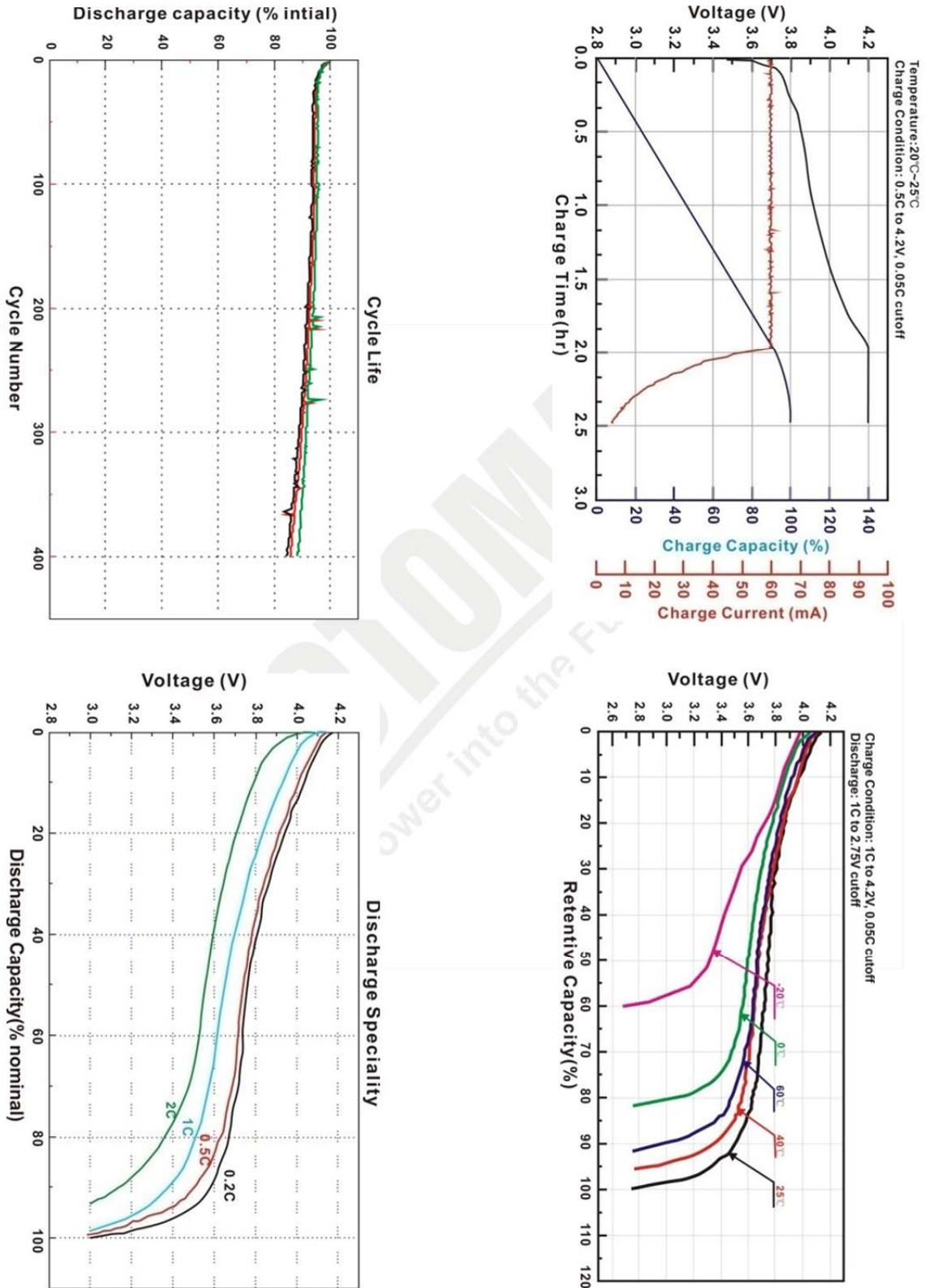

Handling Precautions and Guideline

For LCR (Lithium-ion Cylindrical) Rechargeable Batteries Preface

This document of 'Handling Precautions and Guideline LCR rechargeable batteries shall be applied to the battery cells manufactured by MOTOMA.

Note (1)

The customer is requested to contact MOTOMA, in advance, if and when the customer needs other applications or operating conditions than those described in this document. Additional experimentation may be required to verify performance and safety under such conditions.

Note (2)

MOTOMA will take no responsibility for any accident when the cell is used under other conditions than those described in this Document.

Note (3)

MOTOMA will inform, in a written form, the customer of improvement regarding proper use and handling of the cell, if it is deemed necessary.

1. Charging

1.1 Charging current

Charging current should be less than maximum charge current specified in the Product Specification. Charging with higher current than recommended value may cause damage to battery electrical, mechanical, and safety performance and could lead to heat generation or leakage.

1.2 Charging voltage

Charging shall be done by voltage less than that specified in the Product Specification (4.2V/cell). Charging beyond 4.30V, which is the absolute maximum voltage, must be strictly prohibited. The charger shall be designed to comply with this condition.

It is very dangerous that charging with higher voltage than maximum voltage may cause damage to the cell electrical, mechanical safety performance and could lead to heat generation or leakage.

1.3 Charging temperature

The cell shall be charged within 0°C~45°C range in the product specification.

1.4 Prohibition of reverse charging

Reverse charging is prohibited. The cell shall be connected correctly. The polarity has to be confirmed before wiring. In case of the cell is connected improperly, the cell cannot be charged. Simultaneously, the reverse charging may cause damaging to the cell which may lead to degradation of cell performance and damage the cell safety, and could cause heat generation or leakage.

2. Discharging

2.1 Discharging current

The cell shall be discharged at less than the maximum discharge current specified in the product specification. High discharging current may reduce the discharging capacity significantly or cause over-heat.

2.2 Discharging temperature

The cell shall be discharged within 0°C~45°C range specified in the Product Specification.

2.3 Over-discharging

It should be noted that the cell would be at an over-discharged state by its self-discharge characteristics in case the cell is not used for long time. In order to prevent over-discharging, the cell shall be charged periodically to maintain between 3.7V and 3.9V. Over-discharging may causes loss of cell performance, characteristics, or battery functions.

The charger shall be equipped with a device to prevent further discharging exceeding a cut-off voltage specified in the Product Specification. Also the charger shall be equipped with a device to control the recharging procedures as follows: The cell battery pack shall start with a low current (0.01C) for 15 – 30 minutes, i.e. pre-charging, before rapid charging starts. The rapid charging shall be started after the (individual) cell voltage has been reached above 3.0V within 15 - 30 minutes that can be determined with the use of an appropriate timer for pre-charging. In case the (individual) cell voltage does not rise to 3.0V within the pre-charging time, then the charger shall have functions to stop further charging and display the cell/pack is at abnormal state.

3. Protection Circuit Module

The cell/battery pack shall be with a PCM that can protect cell/battery pack properly. PCM shall have functions of (1) overcharging prevention, (2) over-discharging prevention, (3) over current prevention to maintain safety and prevent significant deterioration of cell performance. The over current can occur by external short circuit

3.1 Overcharging prohibition

Overcharging prohibition function shall stop charging if any one of the cells of the battery pack reaches $4.275 \pm 0.020V$

3.2 Over-discharging prohibition

Over-discharging prevention function shall work to avoid further drop in cell voltage of $3.0 \pm 0.035V$ or less per cell in any cell of the battery pack. It is recommended that the dissipation current of PCM Shall be minimized to 0.5uA or less with the over-discharging prevention..

The protection function shall monitor each bank of the battery pack and control the current all the time.

4. Storage

The cell shall be stored within -20°C~ 45°C range environmental condition.

If the cell has to be storied for a long time (over 3 months), the environmental condition should be:

Temperature: $23 \pm 5^\circ C$; Humidity: $65 \pm 20\% RH$

The voltage for a long time storage shall be 3.7V~3.9V range.

Handling Instructions

1. WARNING !

- ◆ Do not immerse the battery in water or allow it to get wet.
- ◆ Do not use or store the battery near sources of heat such as a fire or heater.
- ◆ Do not use any chargers other than those recommended by MOTOMA POWER.
- ◆ Do not reverse the positive(+) and negative(-) terminals.
- ◆ Do not connect the battery directly to wall outlets or car cigarette-lighter sockets.
- ◆ Do not put the battery into a fire or apply direct heat to it.
- ◆ Do not short-circuit the battery by connecting wires or other metal objects to the positive(+) and negative(-) terminals.
- ◆ Do not pierce the battery casing with a nail or other sharp object, break it open with a hammer, or step on it.
- ◆ Do not strike, throw or subject the battery to physical shock.
- ◆ Do not directly solder the battery terminals.
- ◆ Do not attempt to disassemble or modify the battery in any way.
- ◆ Do not place the battery in a microwave oven or pressurized container.
- ◆ Do not use the battery in combination with primary batteries(such as dry-cell batteries) or batteries of different capacity, type or brand.
- ◆ Do not use the battery if it gives off an odor, generates heat, becomes discolored or deformed, or appears abnormal in any way. If the battery is in use or being recharged, remove it from the device or charger immediately and discontinue use.

2. CAUTION !

- ◆ Do not use or store the battery where is exposed to extremely hot, such as under window of a car in direct sunlight in a hot day. Otherwise, the battery may be overheated. This can also reduce battery performance and/or shorten service life.
- ◆ If the battery leaks and electrolyte gets in your eyes, do not rub them. Instead, rinse them with clean running water and immediately seek medical attention. If left as is, electrolyte can cause eye injury.
- ◆ Use the battery only under the following environmental conditions. Failure to do so can result in reduced performance or a shorten service life. Recharging the battery outside of these temperatures can cause the battery to overheat, explode or catch fire.

Operating environment:

When charging the battery: 0°C~45°C

When discharging the battery: -20°C~60°C

When stored up to 30 days: -20°C~45°C

When stored up to 90 days: -20°C~35°C